

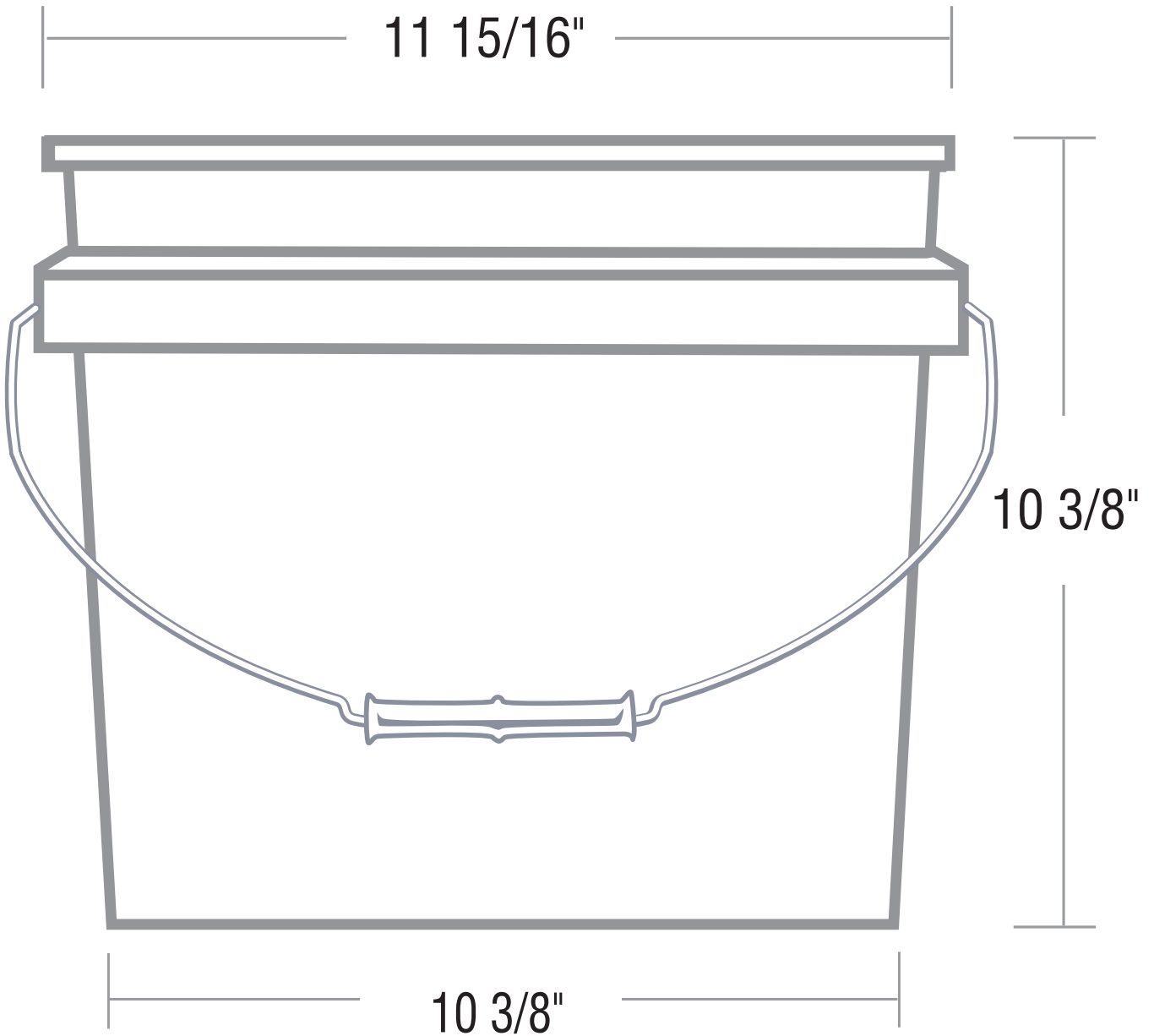

PART NO.: 203105-2

3.5 Gallon Open Head Plastic Pail





Engineering Specification

CAVITY 05

PART NUMBER: 203105-2

3.5 Gallon Open Head Plastic Pail

SPECIFICATIONS

Top Outer Diameter: 11 15/16" +/- 1/32"
 Top Out of Round: 1/8" max
 Height: 10 3/8" +/- 1/8"
 Wall Thickness: 90 mil
 Weight: 725 grams +/- 5 grams
 Overflow Capacity: 3.5 gallons + 76 ounces

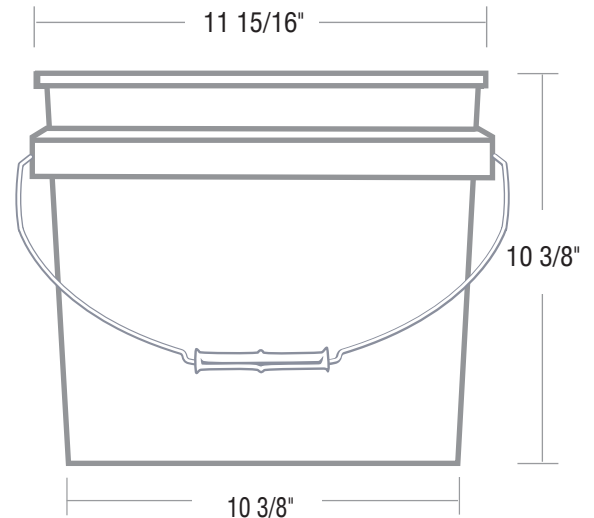

COMPONENTS

Resin: Prime High Density Polyethylene (HDPE)
 Color: Per customer spec
 Handle: 9 gauge galvanized wire with injection molded no-mark plastic grip

PRINT SPECIFICATIONS

Offset Printing Area, below beam: 6 1/8" h x 34" w.
 Above-Beam Printing Area, Front: 1" h x 13" w;
 Rear: 1" h x 5 1/4" w (at top) to 9 1/2" w (at bottom).
 Four color maximum. All pails are shipped flame-treated.

STANDARD PACKAGING

168 per pack (12 stacks of 14 each).
 Pails packed top side up.
 Trays on top and bottom with stretch wrap.
 Applied label shows Part Number and Color, Date, Package Quantity, Shift.
 Package Dimensions: 37" x 49" x 48"
 Weight: 295 lbs. Bulk Density: 5.74 lbs./cubic ft.
 Truckload Quantities: 11,424 (pails only); 8,568 (w/ long skirt lid); 9,072 (short skirt lid)

OPTIONS

FDA 21 CFR 177.1520(c)3.2(a)
 European Union 2002/72 EC

CORRESPONDING LIDS

Part #	Description
205667	Short Skirt w/ Gasket
205973	Short Skirt EZ Tear
205775	Short Skirt w/o Gasket
205876	Long Skirt EZ Tear w/ Gasket
205877	Long Skirt Tear-Tab w/ Gasket
205879	Long Skirt Tear-Tab w/ Gasket
205880/90	Seat Tray/Top Hat

LID OPTIONS

For Gasket Lids:
 Rieke Spout
 Rieke Jr.
 Tint Plug
 Screw Cap
 Screw Cap w/ Tint Plug
 Poly Vent
 Buna Vent